

News & Events

- Press
 - Contacts
- Customer information
- Trade Fairs & Events
- Photos



May 3, 2004

"Offshore" loading for liquefied natural gas via flexible piping

In cooperation with Technip and Eurodim, the KSB Group has developed the first flexible loading system for handling liquefied natural gas (LNG) on the open sea.

The A.L.L.S. ("AMPLITUDE LNG Loading System") comprises a flexible 16" pipe and a coupling system allowing quick connection and emergency release - both are approved by the Bureau Veritas.

The CONNECTIS coupling system combines three major functions in one unit for the first time: quick connection via a Quick Connect / Disconnect Coupler (QCDC), pipe shut-off by an eccentric tandem butterfly valve (ETBV) and the possibility of emergency release via an Emergency Release Coupler (ERC).

The patented eccentric tandem disc makes for an extremely light and compact butterfly valve design. It consists of two valve discs, one positioned directly behind the other. This arrangement reduces the amount of liquefied gas leakage in the event of an emergency release to below two litres.

A synchronization gear prevents the two discs from colliding when actuated. The valve is operated by a double-acting hydraulic actuator. A spring assembly ensures that in the event of hydraulic system failure the valve is closed and uncontrolled leakage of liquefied gas minimized. In the development of the CONNECTIS system, KSB was able to draw on 40 years - experience in equipping liquefied gas tankers with AMRI butterfly valves.

Photo 1: CONNECTIS combines three functions in one unit: mechanical connection to the tanker, gas-tight sealing of the piping connections and the possibility of an emergency release. (KSB Aktiengesellschaft, Frankenthal)

Photo 2: A.L.L.S. is the first flexible ship-to-ship offshore docking system for the loading and unloading of liquefied gas tankers. (KSB Aktiengesellschaft, Frankenthal)

CONNECTIS

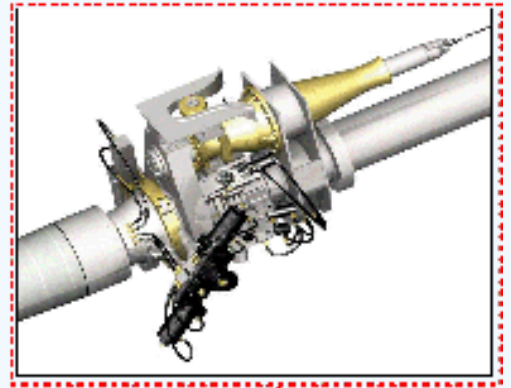

AMPLITUDE LNG Loading System A.L.L.S.

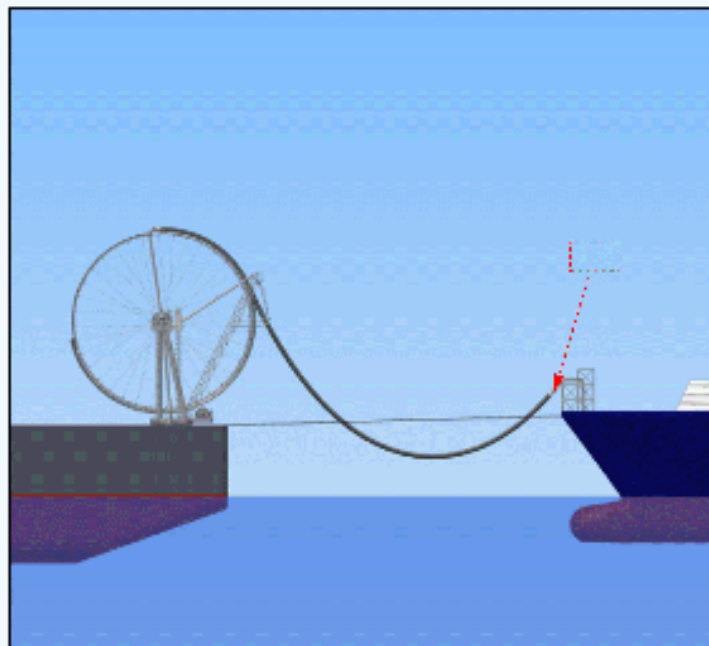

 [print](#)

 [back](#)

 [top](#)

 Your contact person

[english](#) | [deutsch](#) | [français](#)

[Home](#)

© Credits / Disclaimer